

SPECIFICATION SHEET

MODEL: GS-630

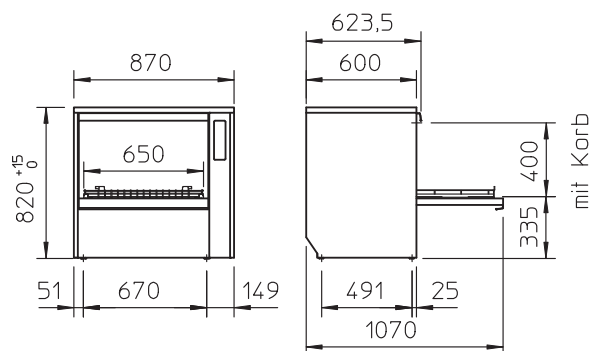

TECHNICAL INFORMATION

Dimensions	860w x 600d x 820h
Rack Dimension	650 X 508
Clear Entry Height	400
Rinse Water Consumption	4.4L Per Cycle

WATER CONNECTIONS

Connection Point	3/4 inch (19mm)
Inlet Temperature	60c Max
Flow Rate	4 L/Min
Flow Pressure	1.0-6.0 bar/Min
Waste Water Hose	39.7 Dia

ELECTRICAL

3 Phase (Standard)	415v 3P 50Hz - 16amp (TCL 8.7Kw)
--------------------	----------------------------------

GENERAL DATA

Weight (Net/Gross)	105/120Kg
Tank Capacity	25L
Noise Emission	70dB(A)
Cycle Times	1.5, 2 & 5 Minutes

STANDARD INCLUSIONS

1x 3phase Lead
1x 1m Flexible Water Connection Hose
1x 1m Flexible Waste Hose
1x 650 x 508 Stainless Steel Rack

STANDARD FEATURES

- Electronic control with colour-coded display
- Elliptical wash fields
- Quadruple filtration system
- Drain pump
- Rinse booster pump
- Detergent and rinse aid pumps